

## **Unit C:** Forest Management

### **Lesson 2:** Measuring Trees

**Student Learning Objectives:** Instruction in this lesson should result in students achieving the following objectives:

1. Describe the common units of measure used in forestry.
2. Explain how to determine the diameter of a standing tree.
3. Explain how to measure the height of standing trees.

**Recommended Teaching Time:** 2 hours

**Recommended Resources:** The following resources may be useful in teaching this lesson:

- A PowerPoint has also been developed with use of this lesson plan
- <http://timberquote.com/education/howto/measure>

### **List of Equipment, Tools, Supplies, and Facilities**

Writing surface  
PowerPoint Projector  
PowerPoint slides  
Transparency Masters  
Biltmore Sticks

**Terms:** The following terms are presented in this lesson (shown in bold italics and on PowerPoint Slide #2):

- Basal area
- Metric Board foot
- Breast height
- Cord
- Cubic meter
- Cubit
- dbh
- Hypsometer
- Linearmeter
- Merchantable height
- Piece

**Interest Approach:** Use an interest approach that will prepare the students for the lesson. Teachers often develop approaches for their unique class and student situations. A possible approach is included here.

On the board write the words “Yield,” “Plant Population,” and “Variety.” Ask students to define these terms. Ask students what these terms refer to. It is expected that they will respond with an answer such as “grain production.” Tell the students just as grain production has its terms, forestry has terms it uses as well to measure production. Lead discussion to first lesson objective.

## Summary of Content and Teaching Strategies

**Objective 1:** Describe the common units of measure used in forestry.

**(PowerPoint Slide #3)**

I. Tree measurements are necessary to determine the volume of wood in each tree. The total of individual tree measurements and volumes provides an inventory of the whole timber stand.

**(PowerPoint Slide #4)**

Timber trees are measured with a variety of units of measure. Some of these units are unique to the wood industry and others are also used for general measuring.

**(PowerPoint Slide #5)**

A. **Metric Board foot**—a unit of measurement represented by a piece of rough wood 0.3048 meter square and 2.54 cm thick. In another words a metric board foot equals 0.0929 square meters. The metric board foot is generally used to measure sawtimber and veneer timber. In surfaced or finished lumber, width and thickness are based on measurements before surfacing or other finishing.

**(PowerPoint Slide #6)**

B. **Cubic meter**—a unit of measurement equal to the volume of a cube of rough wood 0.3048 meter in length on each of its six sides. A cubic meter contains 423.77 board feet. The unit is used to measure all kinds of timber products.

**(PowerPoint Slide #7)**

C. **Cord**—a stack of wood, including air space between pieces, that measures 1.2 meters x 1.2 meters x 2.4 meters, or 3.63 cubic meters. The cord is used to measure pulpwood and fence posts.

**(PowerPoint Slide #8)**

D. **Cubit**—a stack of wood containing 2.8 cubic meters of solid wood.

**(PowerPoint Slide #9)**

E. **Piece**—a unit of measurement that refers to the number or quantity of timber products of a specified dimension.

**(PowerPoint Slide #10)**

F. **Linear meter**—a unit of measurement used to express the length of a product in meters. It is usually a volume of roughly 2 cubic meters.

**(PowerPoint Slide #11)**

G. **Basal area**—a unit of measurement applied to standing timber to indicate the level of stocking. It is the cross-sectional area of trees at **breast height**, or 1.3 meters above the average ground line. Basal area is expressed in square feet. It may apply to individual trees, or it may apply to all trees when it is expressed on a hectare basis.

**\*\*Use TM: C2-1 or PowerPoint Slide #12 to aid in discussion on this topic. Talk about where you use these terms.**

**Objective 2:** Explain how to determine the diameter of a standing tree.  
(PowerPoint Slide #13)

II. The diameter of standing trees is most commonly measured at breast height. This is known as **dbh**. Diameter measurements are taken outside the bark, with deductions made for bark thickness. Tree diameters are usually recorded in even 5 centimeter classes to facilitate volume determination.

(PowerPoint Slide #14)

A. A diameter tape is the most accurate tool for measuring a tree. It is calibrated so that each inch on the diameter side of the tape is actually 7.97966 centimeters in length. Because the tape is calibrated in this way, taking a measurement of the tree's circumference produces the tree's diameter.

(PowerPoint Slide #15)

B. A technique similar to the one described for using a diameter tape can be used for roughly measuring tree diameter with a Biltmore stick. This procedure is based on the geometric principle of similar triangles, with the scale on the stick graduated to read directly in centimeters..

**\*\*Use TM: C2-2 or PowerPoint Slide # 16 to show you how to use a Biltmore stick when measuring the diameter of trees. TM: C2-3 or PowerPoint Slide # 17 gives an illustration of how to use one. If Biltmore sticks are available, take the students to a nearby group of trees to have them try this technique out.**

**Objective 3:** Explain how to measure the height of standing trees.  
(PowerPoint Slide #18)

IV. Tree height may be measured in terms of meters or number of logs or bolts. A tree is measured to either its total height or its merchantable height.

(PowerPoint Slide #19)

**Merchantable height** refers to the usable length of the tree for a specific product and is measured from the stump height to the cut-off point near the top.

(PowerPoint Slide #20)

This cut-off point is located where the stem diameter reaches a minimum size for the product for which the tree is to be harvested or where excess limbs or forks prevent closer utilization. Merchantable height for a sawtimber tree is determined by the number of 4.8 meter logs and half logs that can be cut from a tree.

(PowerPoint Slide #21)

The cut-off point for sawtimber trees varies from 15 to 25 centimeters. Merchantable height for a pulpwood tree is usually tallied to the nearest pulpwood bolt of a given length. This will be 1.2 meters, 1.5 meters, or 1.6 meters, depending on pulp mill specifications. The cut-off point for pulpwood is generally 10 centimeters.

**(PowerPoint Slide #22)**

- A. One instrument that is used to measure tree height is a ***hyprometer***. Hyprometers (graduated in log length) are normally found on the edge tree scale sticks. Most tree scale sticks also have volume tables printed on one of the wide sides. A metric tree stick will measure height to 45 meters by 5 meter log lengths. Length measure is graduated 0 - 100 by consecutive centimeters.

**\*\*Use TM: C2-4 or PowerPoint Slide # 23 to aid in discussion on this topic. If tree sticks are available take the students to the nearest group of trees and measure the height of the trees.**

**Review/Summary:** Use the student learning objectives to summarize the lesson. Have students explain the content associated with each objective. Student responses can be used in determining which objectives need to be reviewed or taught from a different angle. Asking questions over the objectives on PowerPoint Slide # 24 can be used as a review.

**Application:** Conduct a tree survey of the trees located on the school's campus or in a nearby wooded area. Contact a local forester for assistance.

**Evaluation:** Use the following sample test to evaluate the students' comprehension of the material covered in this lesson.

**Answers to Sample Test:**

***Part One: Matching***

1. h
2. f
3. e
4. b
5. d
6. a
7. g
8. c

***Part Two: Completion***

1. diameter tape
2. stem diameter
3. breast height; dbh

## Sample Test

Name \_\_\_\_\_

---

# Test

---

## Unit C Lesson 2: Measuring Trees

### **Part One: Matching**

*Instructions.* Match the term with the correct response. Write the letter of the term by the definition.

- |               |                        |                |
|---------------|------------------------|----------------|
| a. Basal area | d. Merchantable height | g. Cubic foot  |
| b. Cord       | e. dbh                 | h. Linear foot |
| c. Hypsometer | f. Board foot          |                |

- \_\_\_\_\_ 1. A unit of measurement used to express the length of a product in meters. It is usually a volume of about 72 cubic feet (roughly 2 cubic meters).
- \_\_\_\_\_ 2. A unit of measurement represented by a piece of rough wood 0.3048 meter square and 2.54 cm thick.
- \_\_\_\_\_ 3. Diameter at breast height.
- \_\_\_\_\_ 4. A stack of wood, including air space between pieces, that measures 1.2 meters x 1.2 meters x 2.4 meters, or 3.63 cubic meters.
- \_\_\_\_\_ 5. The usable length of the tree for a specific product and the measurement from the stump height to the cut-off point near the top.
- \_\_\_\_\_ 6. A unit of measurement applied to standing timber to indicate the level of stocking.
- \_\_\_\_\_ 7. A unit of measurement equal to the volume of a cube of rough wood 0.3048 meters in length on each of its six sides.
- \_\_\_\_\_ 8. Instrument that is used to measure tree height.

### **Part Two: Completion**

*Instructions.* Provide the word or words to complete the following statements.

1. A \_\_\_\_\_ is the most accurate tool for measuring tree diameter.
2. The cut-off point of a tree is located where the \_\_\_\_\_ reaches a minimum size for the product for which the tree is to be harvested or where excess limbs or forks prevent closer utilization.

3. The diameter of standing trees is most commonly measured at \_\_\_\_\_, also known as \_\_\_\_\_.

TM: C2-1

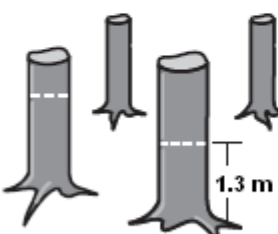
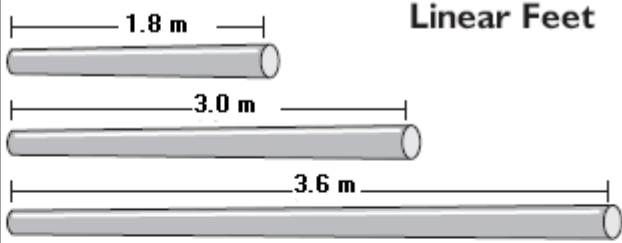
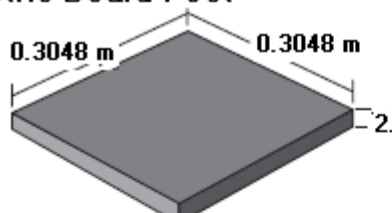
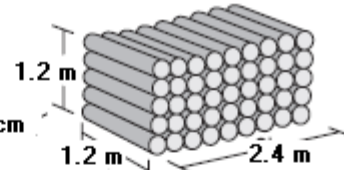
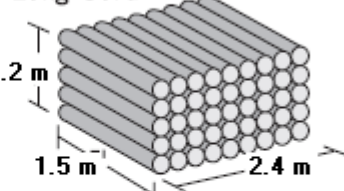
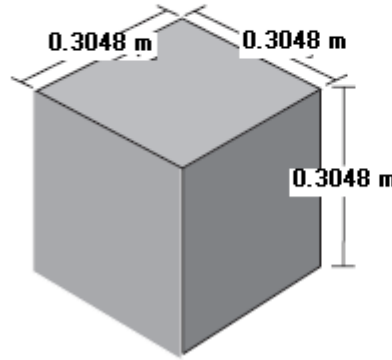
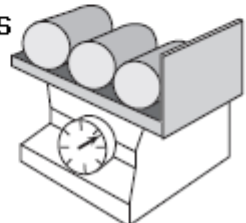
<p><b>Basal Area</b></p> <p>Square feet of all trees measured at dbh on a <b>hectare</b></p> 	<p><b>Linear Feet</b></p> 
<p><b>Metric Board Foot</b></p> 	<p><b>Standard Cord</b></p>  <p><b>Long Cord</b></p> 
<p><b>Cubic Meter</b></p> 	<p><b>Kilograms</b></p> 

## **BILTMORE STICK**

- 1. Hold the stick horizontally, at arm's length (63 centimeters from the eye) and 1.3 meters above the ground.**
- 2. Place the Biltmore Stick against the tree, with the left end of the stick along one edge of the tree. Keep one eye closed.**
- 3. Without moving your head, read the diameter where the right side of the tree intersects the stick**

TM: C2-3

# BILTMORE STICK

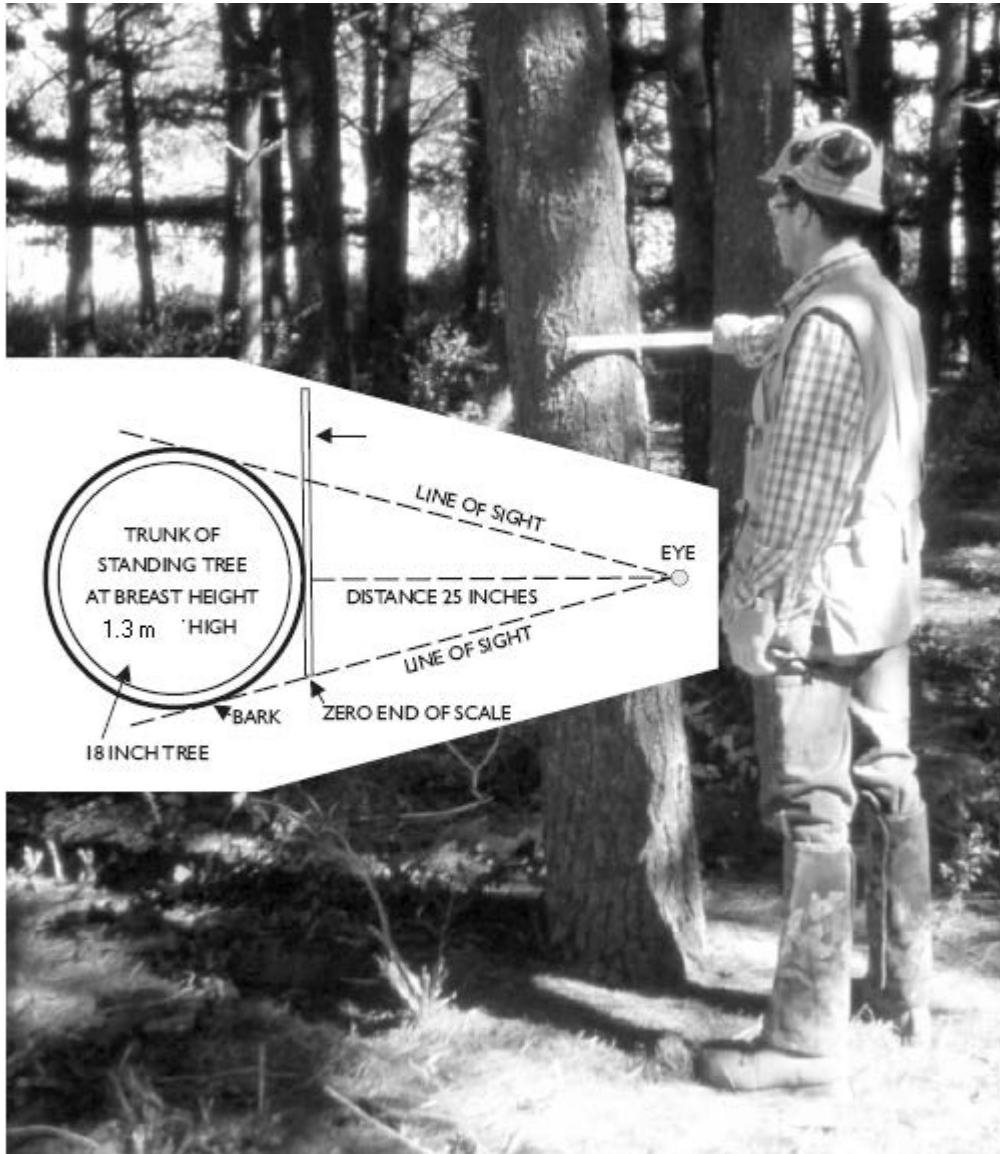



# EXAMPLE OF HYPSONOMETER MEASUREMENT DIRECTIONS

